

WTI Part No. 14536
Rev. B

WTI Console Products

Standard Pinned vs. Straight Pinned RJ45 Serial Ports

Connection Guide



Power & Console Solutions | wti.com

Table of Contents

1. Introduction	1-1
2. Serial Interface Description	2-1
2.1. Serial Port (RS232)	2-2
2.2. Standard Pinned RJ45 Serial Ports	2-2
2.3. Straight Pinned RJ45 Serial Ports	2-3
3. Connecting Devices to RJ45 Serial Ports	3-1
3.1. Straight RJ-45 Cables and Rollover RJ-45 Cables	3-1
3.2. Connecting Devices to Standard Pinout WTI Devices	3-2
3.2.1. Connecting DB-9M DTE Devices - Standard Pinout WTI Devices	3-2
3.2.2. Connecting DB-25F DTE Devices - Standard Pinout WTI Devices	3-3
3.2.3. Connecting DB-25F DCE Devices - Standard Pinout WTI Devices	3-4
3.2.4. Connecting RJ-45 DCE Devices - Standard Pinout WTI Devices	3-5
3.3. Connecting Devices to Straight Pinout WTI Devices	3-6
3.3.1. Connecting DB-9M DTE Devices - Straight Pinout WTI Devices	3-6
3.3.2. Connecting DB-25F DTE Devices - Straight Pinout WTI Devices	3-7
3.3.3. Connecting DB-25F DCE Devices - Straight Pinout WTI Devices	3-8
3.3.4. Connecting RJ-45 DCE Devices - Straight Pinout WTI Devices	3-9
 Appendices:	
A. Customer Service	Apx-1

1. Introduction

This Connection Guide describes the procedure for connecting various network elements to the RJ-45 Serial Ports on WTI DSM Series Console Products and WTI CPM Series Console Server + Switched PDU Products. DSM and CPM Series products are available with either Standard Pinned or Straight Pinned RJ-45 Serial Ports.

Notes:

- *To determine which pinout is present on your WTI Device, first access the CLI command mode as described in the [WTI Firmware Guide](#), and then type /J* and press **[Enter]** to display the Unit Information screen. If the part number shown in the Option field includes the characters, "WPO" then the SetUp Port uses the Straight Pinout format.*
- *For instructions regarding configuration and operation of the WTI Device, please refer to the [WTI Firmware Guide](#).*

About this Guide

Due to the manner in which various web browsers deal with external links in PDF documents, links to external URLs in this document may not function properly depending on the web browser used. For best results, WTI recommends downloading and saving this Connection Guide and then viewing the saved copy with Adobe Acrobat. In addition to providing direct access to external URLs, other document navigation features may also perform more reliably when viewed via Adobe Acrobat rather than your browser's native PDF viewer.

2. Serial Interface Description

Notes:

- WTI Console products are available with either Standard Pinout RJ45 Serial Ports or Straight Pinout RJ45 Serial Ports. To determine which pinout is present on your WTI Device, first access the CLI as described in the [WTI Firmware Guide](#), and then type /J* and press **[Enter]** to display the Unit Information screen. If the part number shown in the Option field includes the characters, "WPO" then the SetUp Port uses the Straight Pinout format
- For information on connecting devices to either type of Serial Port, please refer to [Section 2.2](#), [Section 2.3](#) and [Section 3](#).

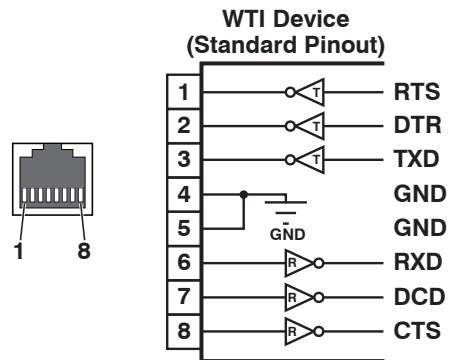

Figure 2.1: RS232 Port Interface (RJ45 - Standard Pinout)

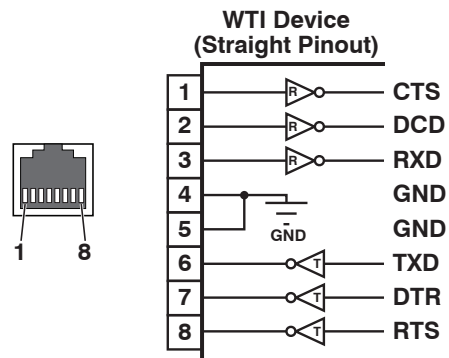

Figure 2.2: RS232 Port Interface (RJ45 - Straight Pinout)

2.1. Serial Port (RS232)

DCD and DTR hardware lines function as follows:

1. **When connected:**
 - a) If either port is set for Modem Mode, the DTR output at either port reflects the DCD input at the other end.
 - b) If *neither* port is set for Modem Mode, DTR output is held high (active).
2. **When not connected:**
 - a) If the port is set for Modem Mode, upon disconnect DTR output is pulsed for 0.5 seconds and then held high.
 - b) If the port is *not* set for Modem Mode, DTR output is controlled by the DTR Output option (Serial Port Parameters Menu, Option 23). Upon disconnect, Option 23 allows DTR output to be held low, held high, or pulsed for 0.5 seconds and then held high.

2.2. Standard Pinned RJ45 Serial Ports

When connecting devices to Standard Pinned Serial Ports, please refer to [Figure 2.1](#) and the table below:

Target Device End	Adapter	Cable	WTI Device End
RJ Serial Console Ports: Cisco Routers, Juniper Routers and Other Network Devices with RJ45 Serial Console Port	(None Required)	RJ45 Rollover Cable: RJ-ROLL (7 Feet) RJ-ROLL-25 (25 Feet)	Standard Pinned RJ45 Console Port
DB9M Serial Console Ports: Linux PC or Liinux Laptop, WTI RSM Series Units, WTI MPC Series Units and Other Devices with a DB9M Serial Console Port	DX9F-DTE-RJ Snap Adapter	RJ45 Straight Cable: RJX-7 (7 Feet) RJX-15 (15 Feet) RJX-25 (25 Feet) RJX-50 (50 Feet)	
DB25F Serial Console Ports: Terminal/DTE and Other Devices with DB25F Serial Console Port	DX25M-DTE-RJ Snap Adapter	RJ45 Straight Cable: RJX-7 (7 Feet) RJX-15 (15 Feet) RJX-25 (25 Feet) RJX-50 (50 Feet)	

Notes:

- For information regarding Straight Pinout Serial Ports, please refer to [Section 2.3](#).
- For RJ45 console ports on target devices that are not pinned as a Cisco interface, try standard Cat5 straight cable. For all other non-standard interfaces, please contact WTI Technical Support for assistance as described in [Appendix A](#). When contacting Technical Support, please be prepared to provide a serial pinout and signal directions for the target interface.

2.3. Straight Pinned RJ45 Serial Ports

When connecting devices to Straight Pinned Serial Ports, please refer to [Figure 2.2](#) and the table below:

Target Device End	Adapter	Cable	WTI Device End
RJ Serial Console Ports: Cisco Routers, Juniper Routers and Other Network Devices with RJ45 Serial Console Port	(None Required)	RJ45 Straight Cable: RJX-7 (7 Feet) RJX-25 (25 Feet)	Straight Pinned RJ45 Serial Console Port
DB9M Serial Console Ports: Linux PC or Liinux Laptop, WTI RSM Series Units, WTI MPC Series Units and Other Devices with a DB9M Serial Console Port	DX9F-DTE-RJ Snap Adapter	RJ45 Rollover Cable: RJ-Roll-7 (7 Feet) RJ-Roll-15 (15 Feet) RJ-Roll-25 (25 Feet) RJ-Roll-50 (50 Feet)	
DB25F Serial Console Ports: Terminal/DTE and Other Devices with DB25F Serial Console Port	DX25M-DTE-RJ Snap Adapter	RJ45 Rollover Cable: RJ-Roll-7 (7 Feet) RJ-Roll-15 (15 Feet) RJ-Roll-25 (25 Feet) RJ-Roll-50 (50 Feet)	

Notes:

- For information regarding Standard Pinout Serial Ports, please refer to [Section 2.2](#).
- For RJ45 console ports on target devices that are not pinned as a Cisco interface, try standard Cat5 straight cable. For all other non-standard interfaces, please contact WTI Technical Support for assistance as described in [Appendix A](#). When contacting Technical Support, please be prepared to provide a serial pinout and signal directions for the target interface.

3. Connecting Devices to RJ45 Serial Ports

This section describes the cables and adapters that are used to connect common devices to the RJ-45 serial ports on Standard Pinned and Straight Pinned WTI devices.

Note: WTI Console products are available with either Standard Pinout RJ45 Serial Ports or Straight Pinout RJ45 Serial Ports. To determine which pinout is present on your WTI Device, first access the CLI as described in the [WTI Firmware Guide](#), and then type `/J*` and press **[Enter]** to display the Unit Information screen. If the part number shown in the Option field includes the characters, "WPO" then the SetUp Port uses the Straight Pinout format.

3.1. Straight RJ-45 Cables and Rollover RJ-45 Cables

The connection examples described in this section include the use of either an RJ-45 Straight cable or RJ-45 Rollover cable. In Straight Cables the pins on each connector are linked to the same pin number on the connector at the other end of the cable; for example, Pin 1 on the right hand connector is linked to Pin 1 on the left hand connector, as shown in [Figure 3.1](#) below.

For Rollover Cables, the order of the pins is reversed; Pin 1 on the right hand connector would be linked to Pin 8 on the left hand connector, as shown in [Figure 3.2](#).

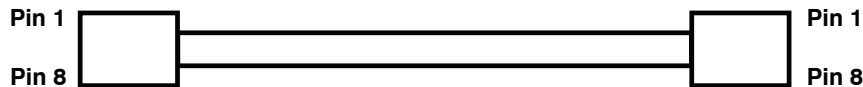

Figure 3.1: Straight Cables

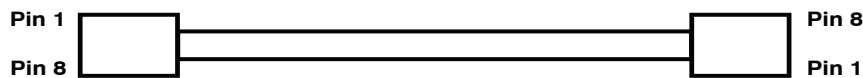

Figure 3.2: Rollover Cables

3.2. Connecting Devices to Standard Pinout WTI Devices

3.2.1. Connecting DB-9M DTE Devices - Standard Pinout WTI Devices

On Standard Pinned WTI Devices, the DX9F-DTE-RJ Snap Adapter can be used with a Straight RJ-45 cable to attach the following DB-9M DTE devices to the RJ-45 Serial Ports:

- PCs and Laptops
- Console Ports on WTI MPC Series Units
- Other Devices with a DB-9M DTE Console Port

When connecting a DB-9M DTE device to an RJ-45 Serial Port on a Standard Pinned WTI Device, please refer to [Figure 3.3](#) and [Figure 3.4](#) below:

Notes:

- *WTI Console products are available with either Standard Pinned RJ45 Serial Ports or Straight Pinned RJ45 Serial Ports. To determine which pinout is present on your WTI Device, first access the CLI as described in the [WTI Firmware Guide](#), and then type /J* and press **[Enter]** to display the Unit Information screen. If the part number shown in the Option field includes the characters, "WPO" then the SetUp Port uses the Straight Pinout format.*
- *For a information regarding connecting devices to WTI units that include Straight Pinned serial ports, please refer to [Section 3.3](#).*
- *For a description of the Standard Pinout, please refer to [Section 2](#).*

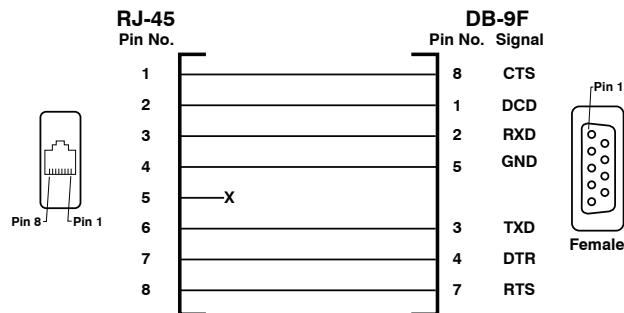

Figure 3.3: DX9F-DTE-RJ Snap Adapter Interface

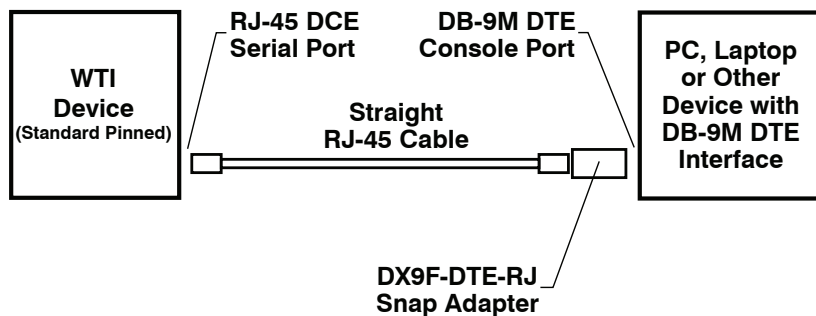

Figure 3.4: Connecting DB-9M DTE Devices to Standard Pinned WTI Devices

3.2.2. Connecting DB-25F DTE Devices - Standard Pinout WTI Devices

On Standard Pinned WTI Devices, the DX25M-DTE-RJ Snap Adapter can be used with a Straight RJ-45 cable to attach the most DB-25F DTE devices to the WTI Device's RJ-45 Serial Ports.

When connecting a DB-25F DTE device to an RJ-45 Serial Port on a Standard Pinned WTI Device, please refer to [Figure 3.5](#) and [Figure 3.6](#) below:

Notes:

- WTI Devices are available with either Standard Pinned RJ45 Serial Ports or Straight Pinned RJ45 Serial Ports. To determine which pinout is present on your WTI Device, first access the CLI as described in the [WTI Firmware Guide](#), and then type `/J*` and press **[Enter]** to display the Unit Information screen. If the part number shown in the Option field includes the characters, "WPO" then the SetUp Port uses the Straight Pinout format.
- For a information regarding connecting devices to WTI units that include Straight Pinned serial ports, please refer to [Section 3.3](#).
- For a description of the Standard Pinout, please refer to [Section 2](#).

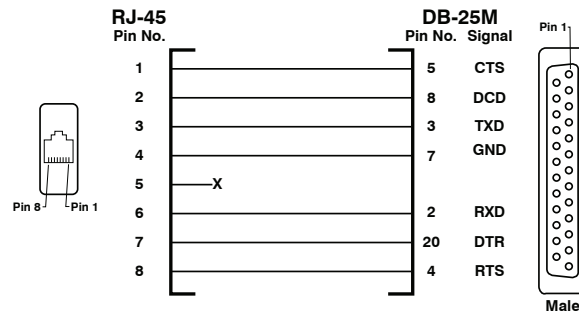

Figure 3.5: DX25M-DTE-RJ Snap Adapter Interface

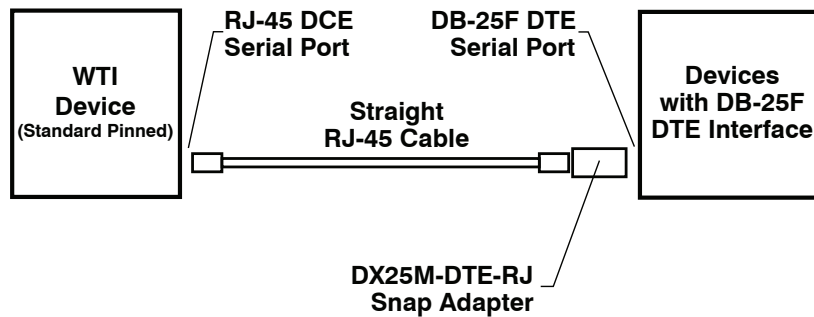

Figure 3.6: Connecting DB-25F DTE Devices to Standard Pinned WTI Devices

3.2.3. Connecting DB-25F DCE Devices - Standard Pinout WTI Devices

On Standard Pinned WTI Devices, the DX25M-DCE-RJ Snap Adapter can be used with a Straight RJ-45 cable to attach the following DB-25F DCE devices to the WTI Device's RJ-45 Serial Ports:

- External Modems with DB-25F DCE Serial Port
- Other Devices with a DB-25F DCE Console Port

When connecting a DB-25F DCE device to an RJ-45 Serial Port on a Standard Pinned WTI Console unit, please refer to [Figure 3.7](#) and [Figure 3.8](#) below:

Notes:

- WTI Console products are available with either Standard Pinned RJ45 Serial Ports or Straight Pinned RJ45 Serial Ports. To determine which pinout is present on your WTI Device, first access the CLI as described in the [WTI Firmware Guide](#), and then type `/J*` and press **[Enter]** to display the Unit Information screen. If the part number shown in the Option field includes the characters, "WPO" then the SetUp Port uses the Straight Pinout format.
- For a information regarding connecting devices to WTI units that include Straight Pinned serial ports, please refer to [Section 3.3](#).
- For a description of the Standard Pinout, please refer to [Section 2](#).

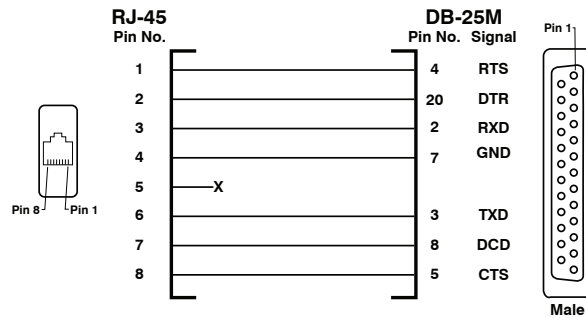

Figure 3.7: DX25M-DCE-RJ Snap Adapter Interface

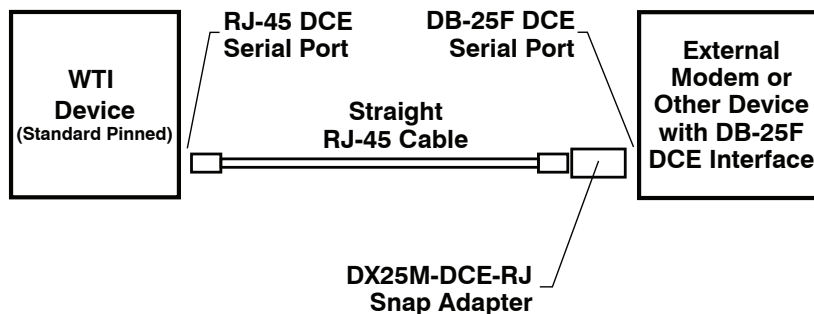

Figure 3.8: Connecting DB-25F DCE Devices to Standard Pinned WTI Devices

3.2.4. Connecting RJ-45 DCE Devices - Standard Pinout WTI Devices

On Standard Pinned WTI Devices, an RJ-ROLL Rollover cable can be used to connect the following RJ-45 DCE devices to the WTI Device's RJ-45 Serial Ports:

- Cisco Routers with RJ-45 DCE Console Port
- Sun Routers with RJ-45 DCE Console Port
- Other Devices with RJ-45 DCE Console Port

When connecting an RJ-45 DCE device to an RJ-45 serial port on a Standard Pinned WTI Device, please refer to [Figure 3.9](#) below:

Notes:

- *WTI Console Products are available with either Standard Pinned RJ45 Serial Ports or Straight Pinned RJ45 Serial Ports. To determine which pinout is present on your WTI Device, first access the CLI as described in the [WTI Firmware Guide](#), and then type /J* and press **[Enter]** to display the Unit Information screen. If the part number shown in the Option field includes the characters, "WPO" then the SetUp Port uses the Straight Pinout format.*
- *For a information regarding connecting devices to WTI units that include Straight Pinned serial ports, please refer to [Section 3.3](#).*
- *For a description of the Standard Pinout, please refer to [Section 2](#).*

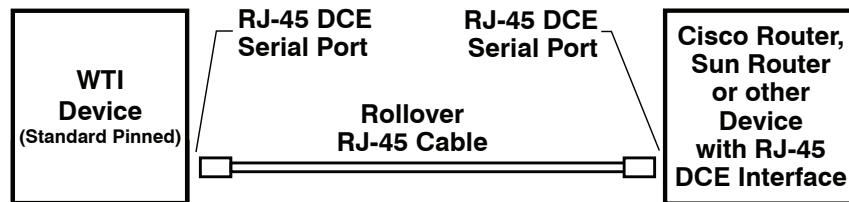

Figure 3.9: Connecting RJ-45 DCE Devices to Standard Pinned WTI Devices

3.3. Connecting Devices to Straight Pinout WTI Devices

3.3.1. Connecting DB-9M DTE Devices - Straight Pinout WTI Devices

On Straight Pinout WTI Devices, the DX9F-DTE-RJ Snap Adapter can be used with an RJ-Roll Rollover cable to attach the following DB-9M DTE devices to the WTI Device's RJ-45 Serial Ports:

- PCs and Laptops
- Console Ports on WTI MPC Series Units
- Other Devices with a DB-9M DTE Console Port

When connecting a DB-9M DTE device to an RJ-45 Serial Port on a Straight Pinned WTI Device, please refer to [Figure 3.10](#) and [Figure 3.11](#) below:

Notes:

- *WTI Console Products are available with either Standard Pinned RJ45 Serial Ports or Straight Pinned RJ45 Serial Ports. To determine which pinout is present on your WTI Device, first access the CLI as described in the [WTI Firmware Guide](#), and then type /J* and press **[Enter]** to display the Unit Information screen. If the part number shown in the Option field includes the characters, "WPO" then the SetUp Port uses the Straight Pinout format.*
- *For a information regarding connecting devices to WTI units that include Standard Pinned serial ports, please refer to [Section 3.2](#).*
- *For a description of the Straight Pinout, please refer to [Section 2](#).*

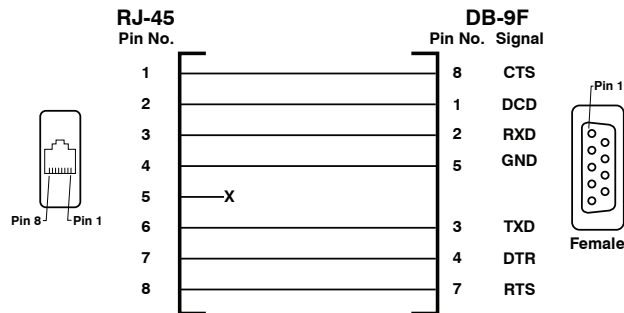

Figure 3.10: DX9F-DTE-RJ Snap Adapter Interface

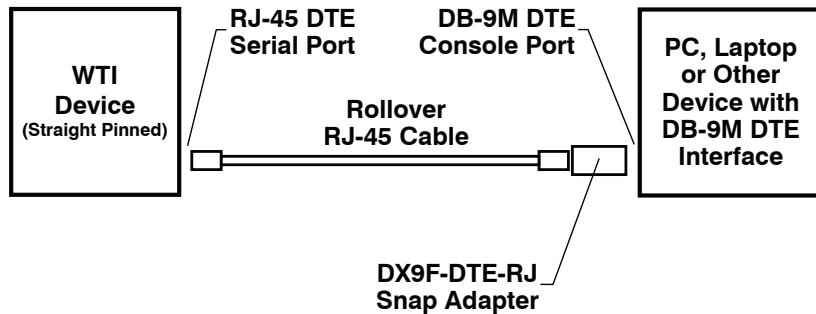

Figure 3.11: Connecting DB-9M DTE Devices to Straight Pinned WTI Devices

3.3.2. Connecting DB-25F DTE Devices - Straight Pinout WTI Devices

On Straight Pinned WTI Devices, the DX25M-DTE-RJ Snap Adapter can be used with an RJ-Roll Rollover cable to attach the most DB-25F DTE devices to the WTI Device's RJ-45 Serial Ports.

When connecting a DB-25F DTE device to an RJ-45 Serial Port a Straight Pinned WTI Device, please refer to [Figure 3.12](#) and [Figure 3.13](#) below:

Notes:

- WTI Console products are available with either Standard Pinned RJ45 Serial Ports or Straight Pinned RJ45 Serial Ports. To determine which pinout is present on your WTI Device, first access the CLI as described in the [WTI Firmware Guide](#), and then type `/J*` and press **[Enter]** to display the Unit Information screen. If the part number shown in the Option field includes the characters, "WPO" then the SetUp Port uses the Straight Pinout format.
- For a information regarding connecting devices to WTI Console units that include Standard Pinned serial ports, please refer to [Section 3.2](#).
- For a description of the Straight Pinout, please refer to [Section 2](#).

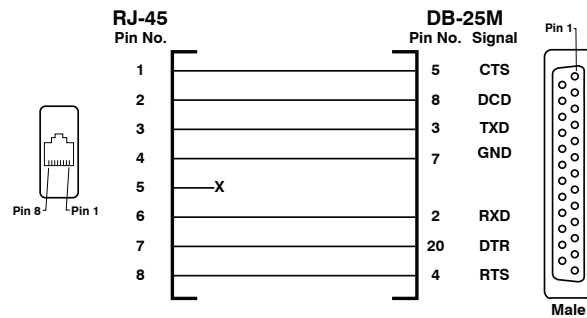

Figure 3.12: DX25M-DTE-RJ Snap Adapter Interface

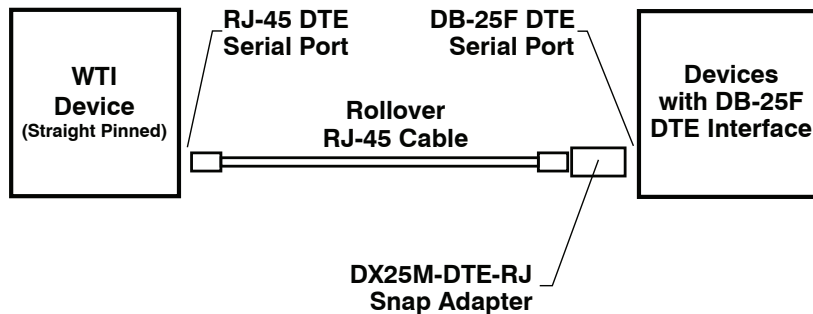

Figure 3.13: Connecting DB-25F DTE Devices to Straight Pinned WTI Devices

3.3.3. Connecting DB-25F DCE Devices - Straight Pinout WTI Devices

On Straight Pinned WTI Devices, the DX25M-DCE-RJ Snap Adapter can be used with an RJ-Roll Rollover cable to attach the following DB-25F DCE devices to the WTI Device's RJ-45 Serial Ports:

- External Modems with DB-25F DCE Serial Port
- Other Devices with a DB-25F DCE Console Port

When connecting a DB-25F DCE device to an RJ-45 Serial Port on a Straight Pinned WTI Device, please refer to [Figure 3.14](#) and [Figure 3.15](#) below:

Notes:

- WTI Console products are available with either Standard Pinned RJ45 Serial Ports or Straight Pinned RJ45 Serial Ports. To determine which pinout is present on your WTI Device, first access the CLI as described in the [WTI Firmware Guide](#), and then type `/J*` and press **[Enter]** to display the Unit Information screen. If the part number shown in the Option field includes the characters, "WPO" then the SetUp Port uses the Straight Pinout format.
- For a information regarding connecting devices to WTI units that include Standard Pinned serial ports, please refer to [Section 3.2](#).
- For a description of the Straight Pinout, please refer to [Section 2](#).

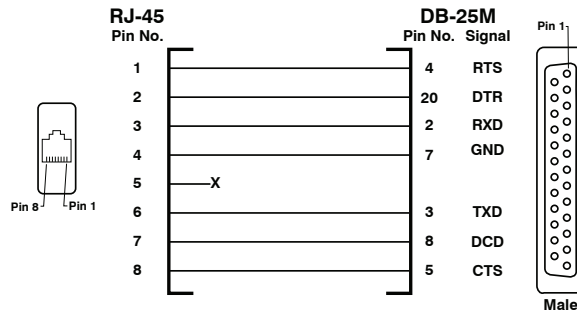

Figure 3.14: DX25M-DCE-RJ Snap Adapter Interface

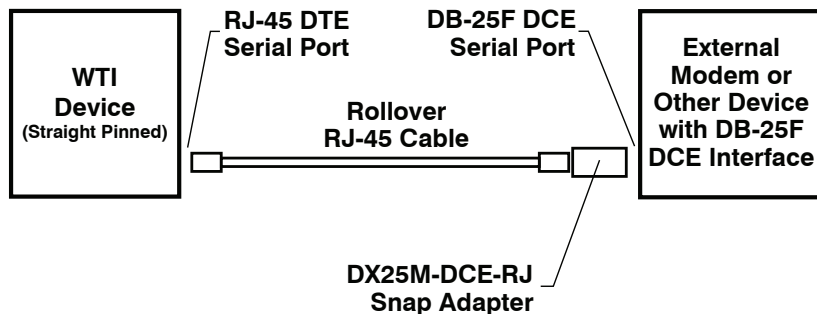

Figure 3.15: Connecting DB-25F DCE Devices to Straight Pinned WTI Devices

3.3.4. Connecting RJ-45 DCE Devices - Straight Pinout WTI Devices

On Straight Pinned WTI Devices, a Straight RJ-45 cable can be used to connect the following RJ-45 DCE devices to the WTI Device's RJ-45 Serial Ports:

- Cisco Routers with RJ-45 DCE Console Port
- Sun Routers with RJ-45 DCE Console Port
- Other Devices with RJ-45 DCE Console Port

When connecting an RJ-45 DCE device to an RJ-45 serial port on a Straight Pinned WTI Console unit, please refer to [Figure 3.16](#) below:

Notes:

- *WTI Console Products are available with either Standard Pinned RJ45 Serial Ports or Straight Pinned RJ45 Serial Ports. To determine which pinout is present on your WTI Device, first access the CLI as described in the [WTI Firmware Guide](#), and then type /J* and press **[Enter]** to display the Unit Information screen. If the part number shown in the Option field includes the characters, "WPO" then the SetUp Port uses the Straight Pinout format.*
- *For a information regarding connecting devices to WTI Console units that include Standard Pinned serial ports, please refer to [Section 3.2](#).*
- *For a description of the Straight Pinout, please refer to [Section 2](#).*

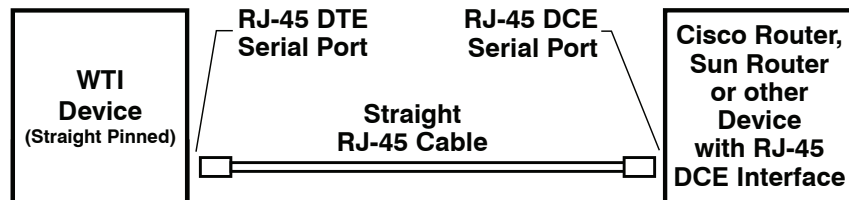

Figure 3.16: Connecting RJ-45 DCE Devices to Standard Pinned WTI Devices

Appendix A. Customer Service

Customer Service hours are from 8:00 AM to 5:00 PM, PST, Monday through Friday. When calling, please be prepared to give the name and make of the unit, its serial number and a description of its symptoms. If the unit should need to be returned for factory repair it must be accompanied by a Return Authorization number from Customer Service.

WTI Customer Service
5 Sterling
Irvine, California 92618

Local Phone: (949) 586-9950
Toll Free Service Line: 1-888-280-7227
Service Fax: (949) 583-9514

Email: service@wti.com

Trademark and Copyright Information

WTI and Western Telematic are trademarks of Western Telematic Inc.. All other product names mentioned in this publication are trademarks or registered trademarks of their respective companies.

Information and descriptions contained herein are the property of Western Telematic Inc.. Such information and descriptions may not be copied, disseminated, or distributed without the express written consent of Western Telematic Inc..

© Copyright Western Telematic Inc., 2019.

June, 2019

Part Number: 14536, Revision: B

Trademarks and Copyrights Used in this Manual

All trademarks mentioned in this manual are acknowledged to be the property of the trademark owners.